

Handvevar, raka, liknande DIN 469

Artikelbeskrivning/produktbilder



Beskrivning

Material:

Vevarm i tempererat gjutjärn eller kulgrafitgjutgods.

Utförande:

Blästrat.

Ritningsinformation:

Form D: Handvev med vridbart roterande handtag

Form F: handvev med fast roterande handtag

Ritningar

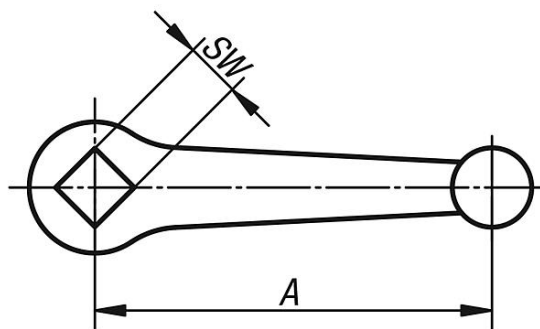
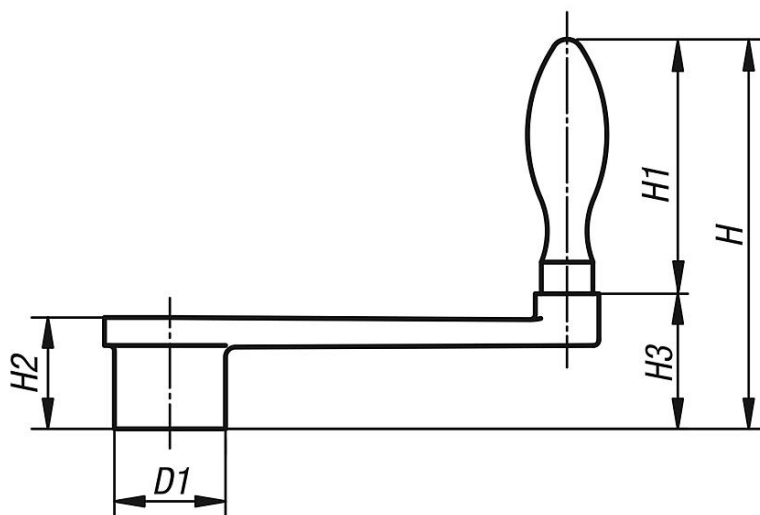

Artikelöversikt

Handvevar, raka, liknande DIN 469

Handvevar, raka, liknande DIN 469

Artikelöversikt

Beställningsnr.	Form	A	D1	H	H1	H2	H3	SW	Diameter roterande handtag
K0685.206X10	D	63	20	80	52	20	28	10+0,2	16
K0685.208X10	D	80	24	98	65	24	33	10+0,2	20
K0685.208X12	D	80	24	98	65	24	33	12+0,2	20
K0685.210X12	D	100	28	102	65	28	37	12+0,2	20
K0685.210X14	D	100	28	102	65	28	37	14+0,3	20
K0685.212X14	D	125	34	120	80	34	40	14+0,3	25
K0685.212X17	D	125	34	120	80	34	40	17+0,3	25
K0685.216X17	D	160	37	131	83	38	48	17+0,3	25
K0685.216X19	D	160	37	131	83	38	48	19+0,3	25
K0685.220X19	D	200	40	158	105	44	53	19+0,3	32
K0685.220X22	D	200	40	158	105	44	53	22+0,3	32
K0685.106X10	F	63	20	80	52	20	28	10+0,2	16
K0685.108X10	F	80	24	98	65	24	33	10+0,2	20
K0685.108X12	F	80	24	98	65	24	33	12+0,2	20
K0685.110X12	F	100	28	102	65	28	37	12+0,2	20
K0685.110X14	F	100	28	102	65	28	37	14+0,3	20
K0685.112X14	F	125	34	120	80	34	40	14+0,3	25
K0685.112X17	F	125	34	120	80	34	40	17+0,3	25
K0685.116X17	F	160	37	131	83	38	48	17+0,3	25
K0685.116X19	F	160	37	131	83	38	48	19+0,3	25
K0685.120X19	F	200	40	158	105	44	53	19+0,3	32
K0685.120X22	F	200	40	158	105	44	53	22+0,3	32