

Clamping angles Type I

Item description/product images

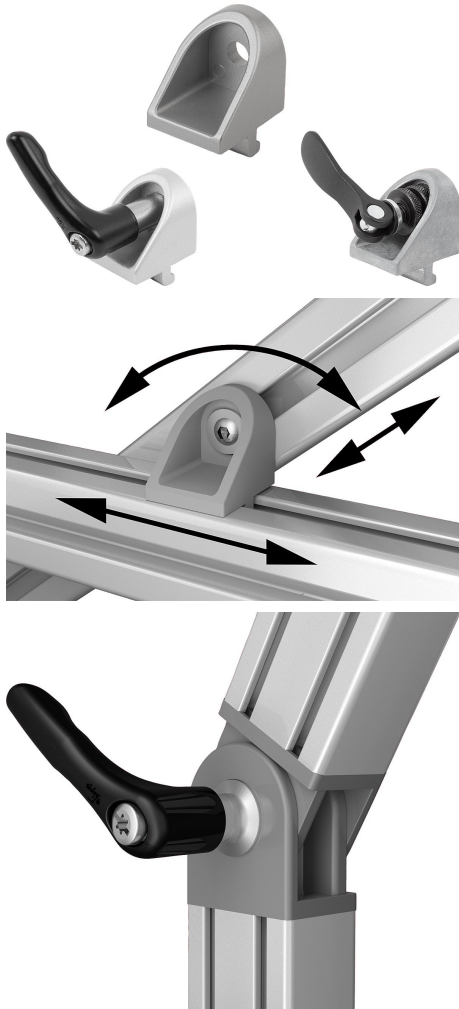

Description

Material:

Clamping angle die-cast zinc.
Handle die-cast zinc DIN EN 12844.
Metal parts stainless steel 1.4305.

Version:

Clamping angle painted aluminium tone.
Handle powder-coated.
Stainless steel bright.

Note:

The clamping angles are used for connecting two profiles of the same series that have contact on the side faces and cross at any angle.

Loosening the screw releases both clamps allowing free rotation and sliding along the slots.

The clamping angles are generally used in pairs or in combination with a joint angle.

Clamping angles Type I

Drawings

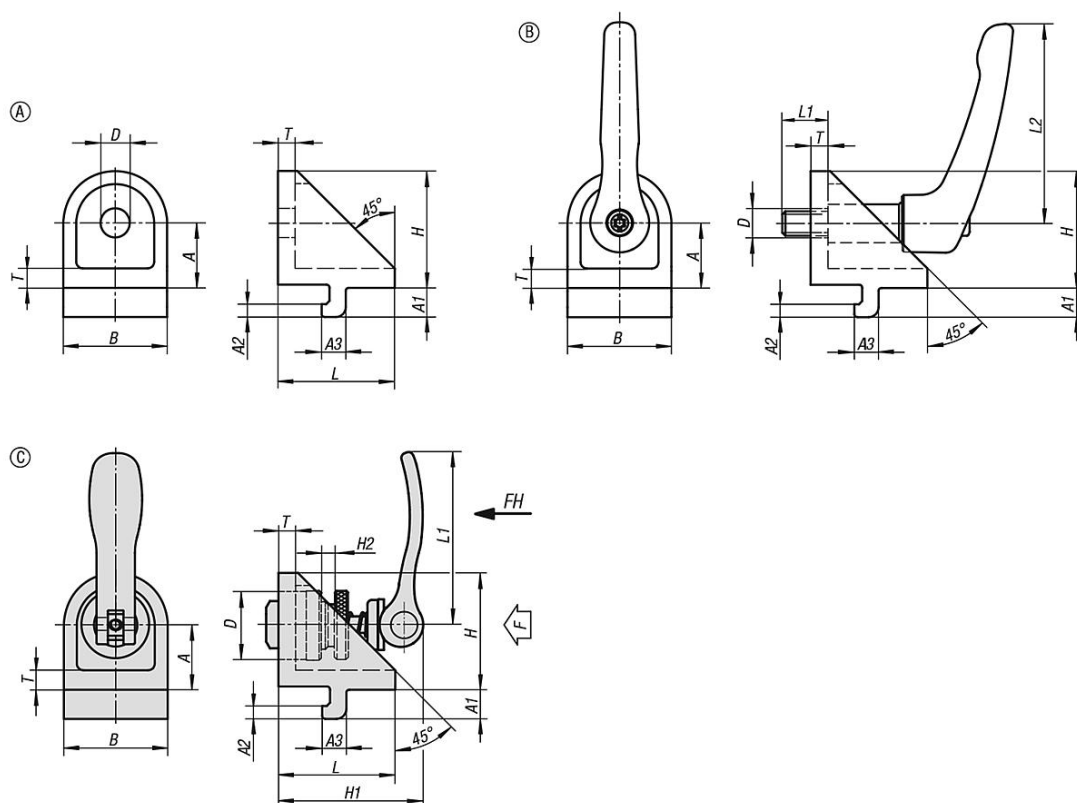

Overview of items

Clamping angles Type I

Order No.	Type	Slot width	Form	Version 1	A	A1	A2	A3	B	D	D1	H	H1	H2	L	L1	L2	T
K1049.06	I	6	A	-	15	6,3	3	5,7	24	7	-	27	-	-	27	-	-	5
K1049.08	I	8	A	-	20	9	4	7,5	32	9	-	36	-	-	36	-	-	6
K1049.0606	I	6	B	with clamping lever	15	6,3	3	5,7	24	7	M6	27	-	-	27	13	40	5
K1049.0808	I	8	B	with clamping lever	20	9	4	7,5	32	9	M8	36	-	-	36	18	65	6
K1049.0615	I	6	C	with eccentric clamp	15	6,3	3	5,7	24	15	-	27	34	6	27	36,2	-	5
K1049.0820	I	8	C	with eccentric clamp	20	9	4	7,5	32	20	-	36	44	8	36	52,3	-	6